

$$(ab)^n = a^n b^n$$

$$a^2 + b^2 = c^2$$

$$L = \frac{\pi R}{2}$$

$$\lim_{x \rightarrow x_0} [f(x) + g(x)]$$

$$S = \sqrt{r^2 + h^2}$$



$$b^2 = (a+b)^2$$



$$\pi = 3.1415926$$

$$a(b+c) = ab+ac$$

$$y_0 = b x_0$$

$$\sec(-x) = \sec(x)$$

$$s = \sqrt{r^2 + h^2}$$

$$|a| = |-a|$$

$$\pi = 3.1415926$$



$$C = 2\pi r$$



$$\frac{n!}{n!(n-r)!}$$

$$|a| = |-a|$$

$$A + B + C = 180^\circ$$

$$\log_a x = \frac{\log_e x}{\log_e a}$$



$$\sin \frac{\alpha}{2} = \frac{\sin \alpha}{2}$$

$$L = \frac{\pi R}{2}$$

$$\lim_{x \rightarrow x_0} [f(x) + g(x)]$$

$$y = f(x)$$

$$a^2 = (a+b)^2$$

$$\text{ctg } \frac{\alpha}{2} = \frac{1 + \cos \alpha}{\sin \alpha}$$

$$(ab)^n = a^n b^n$$

$$C = 2\pi R$$



$$\Delta ABC \sim \Delta ADC$$

$$A = s^2$$

$$C = 2\pi R$$

$$a^2 + b^2 = c^2$$



$$V = \frac{1}{3} \pi r^2 h$$

$$\log_a x = \frac{\log_e x}{\log_e a}$$

$$ab + ac = a(b+c)$$

$$(ab)^n = a^n b^n$$

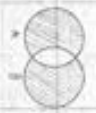

$$\frac{n!}{n!(n-r)!}$$

$$\Delta ABC \sim \Delta ADC$$

$$a+b+c = 180^\circ$$

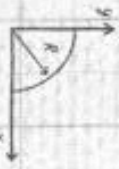

$$\frac{\sin A}{a} = \frac{\sin B}{b} = \frac{\sin C}{c}$$

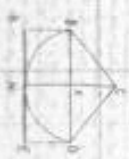

$$\frac{a+b}{c} = \frac{a}{c} + \frac{b}{c}$$

$$y_0 = b x_0$$

$$C = 2\pi r$$

$$y = f(x)$$

$$\text{ctg } \frac{\alpha}{2} = \frac{1 + \cos \alpha}{\sin \alpha}$$

$$ab + ac = a(b+c)$$

$$V = \frac{1}{3} \pi r^2 h$$

$$a(b+c) = ab+ac$$



Amir Syarif





“WHAT,
are you going to DO, Doc?”

Leanne Simpson

Levi S. H.

**My mission :
To help change healthcare
from the outside-in with data and,
for now, 'some' AI**

Luc Engel

35%-54%
Nurses and Doctors

79% GP
Primary care physicians



REIMAGINING WORKPLACE HEALTH & WELLBEING

People are routinely overwhelmed, overloaded and stressed



40%

of all employees face high stress in their jobs, negatively affecting their productivity, health and family stability. **



60%

of employees aren't fully present when they show up at work.*



74%

of employees feel work is the leading cause of stress.*



32%

of employees are highly disengaged in their jobs.*



17%

of young employees (25-35) has a burn-out in the Netherlands.*



96%

of U.S. CXOs feel burn out.*



Leanne Supton

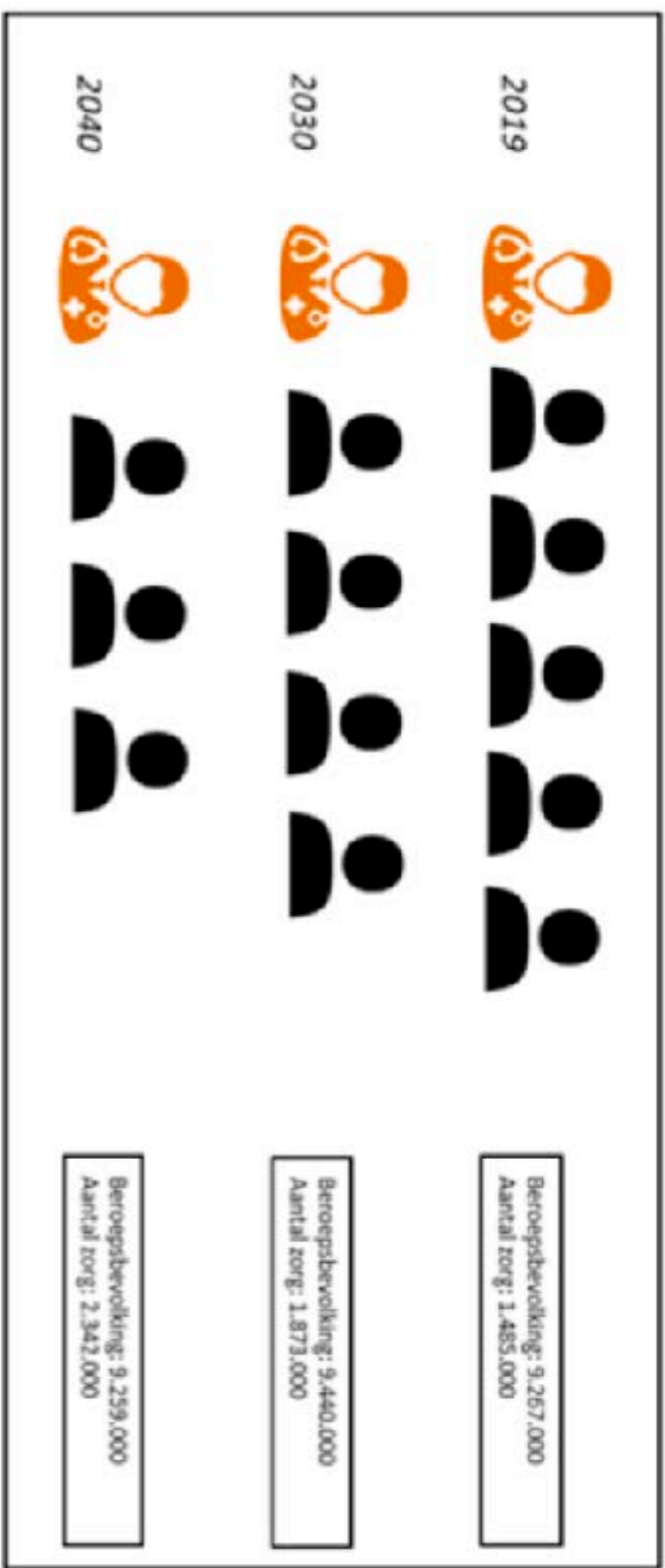



Lucas Saphire

Chemo's : cancelled
Operations : postponed
Non-urgents : cancelled



Lucas S. Cunha

Luciano Caputo



Think Different



“ More healthcare ...
is not the solution for
the current challenges,
... more health is! ”

Lavinia Sanyal
Transform Health

Luisa S. Kaplan

Drivers of health Where we invest

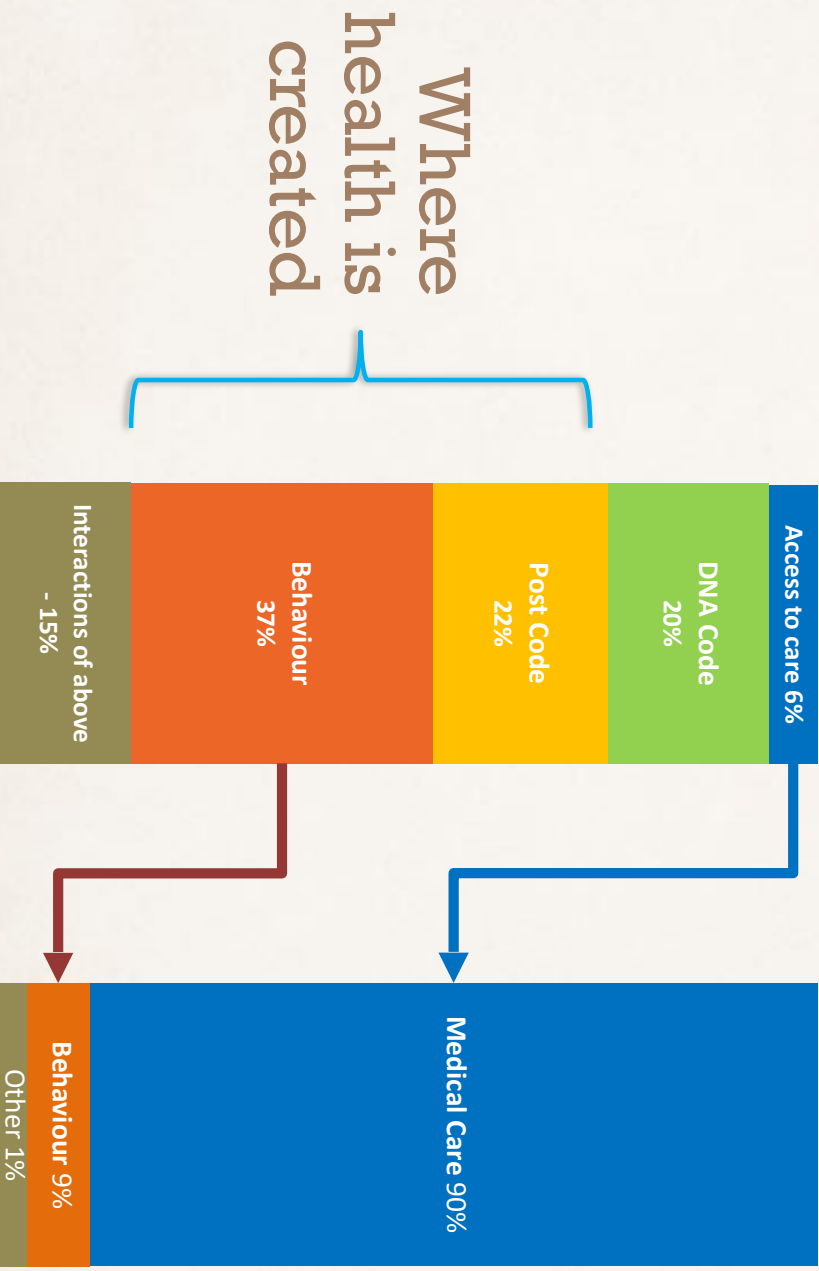

Where health is created

"Patients spend 99.5% of their time outside of the clinic"

-Aetna CEO Bertolini

"Health professional students spend <2.5% of hands-on training time seeing patients at home & at work"

- unpublished, Dr. Weed, APHA-Chicago, 2015

Source : NEHI Analytics (2013) <https://www.tbt.org/-/media/tbtorg/files/reports/lhphe-3rd-report-card.pdf>

Luciano Sgrillo



Luisa Caplan



CNN

KTLA

**MY
POSITIVE
HEALTH**

- Taking care of yourself
- Knowing your limitations
- Knowledge of health
- Managing time
- Managing money
- Being able to work
- Being able to ask for help

- Social contacts
- Being taken seriously
- Doing fun things together
- Having the support from others
- Sense of belonging
- Doing meaningful things
- Being interested in society



**DAILY
FUNCTIONING**



PARTICIPATION



BODILY FUNCTIONS

- Feeling healthy
- Feeling fit
- No physical complaints and/or pain
- Sleeping
- Eating
- Sexuality
- Physical condition
- Physical activity



**MENTAL
WELL-BEING**

- Being able to remember things
- Being able to concentrate
- Being able to communicate
- Being cheerful
- Accepting yourself
- Being able to handle change
- Feeling in control



MEANINGFULNESS

- Having a meaningful life
- Having a zest for life
- Pursuing ideals
- Feeling confident
- Accepting life
- Being grateful
- Lifelong learning



QUALITY OF LIFE

- Enjoyment
- Being happy
- Feeling good
- Feeling well-balanced
- Feeling safe
- Intimacy
- Housing circumstances
- Having enough money

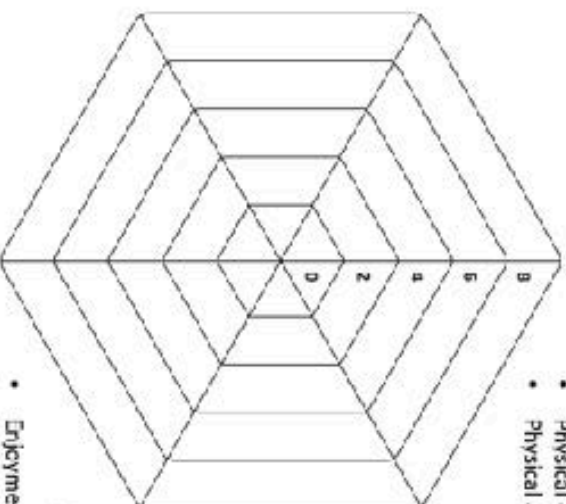

Louise Griffin

Lucian Craythorn

U N D E R S T A N D I N G B O S T O N

E X E C U T I V E S U M M A R Y

The Boston Paradox:

Lots of Health Care, Not Enough Health



Research by the
New England Healthcare Institute
Boston, Massachusetts

UBI The Boston
Foundation
1000 EAST 60TH STREET, SUITE 100
BOSTON, MA 02131
NEHI The National
Healthcare Institute

The Boston Foundation
June 2007

Lucien Engel

Science fiction Is now becoming Science



@lucienengalen 2017 The End of the beginning



Xprize

Explore content 

About the journal 

Publish with us 

[nature](#) > [nature medicine](#) > [articles](#) > [article](#)

Article | [Open access](#) | Published: 31 August 2024

Digital consults in heart failure care: a randomized controlled trial

[Jelle P. Man](#), [Maarten A. C. Koole](#), [Paola G. Meregalli](#), [M. Louis Handoko](#), [Susan Stienen](#), [Frederik J. de Lange](#), [Michiel M. Winter](#), [Marlies P. Schijven](#), [Wouter E. M. Kok](#), [Dorianne I. Kuipers](#), [Pim van der Harst](#), [Folkert W. Asselbergs](#), [Aeilko H. Zwinderman](#), [Marcel G. W. Dijkgraaf](#), [Steven A. J. Chamuleau](#) & [Mark J. Schuuring](#) 

[Nature Medicine \(2024\)](#) | [Cite this article](#)

7 Altmetric | [Metrics](#)

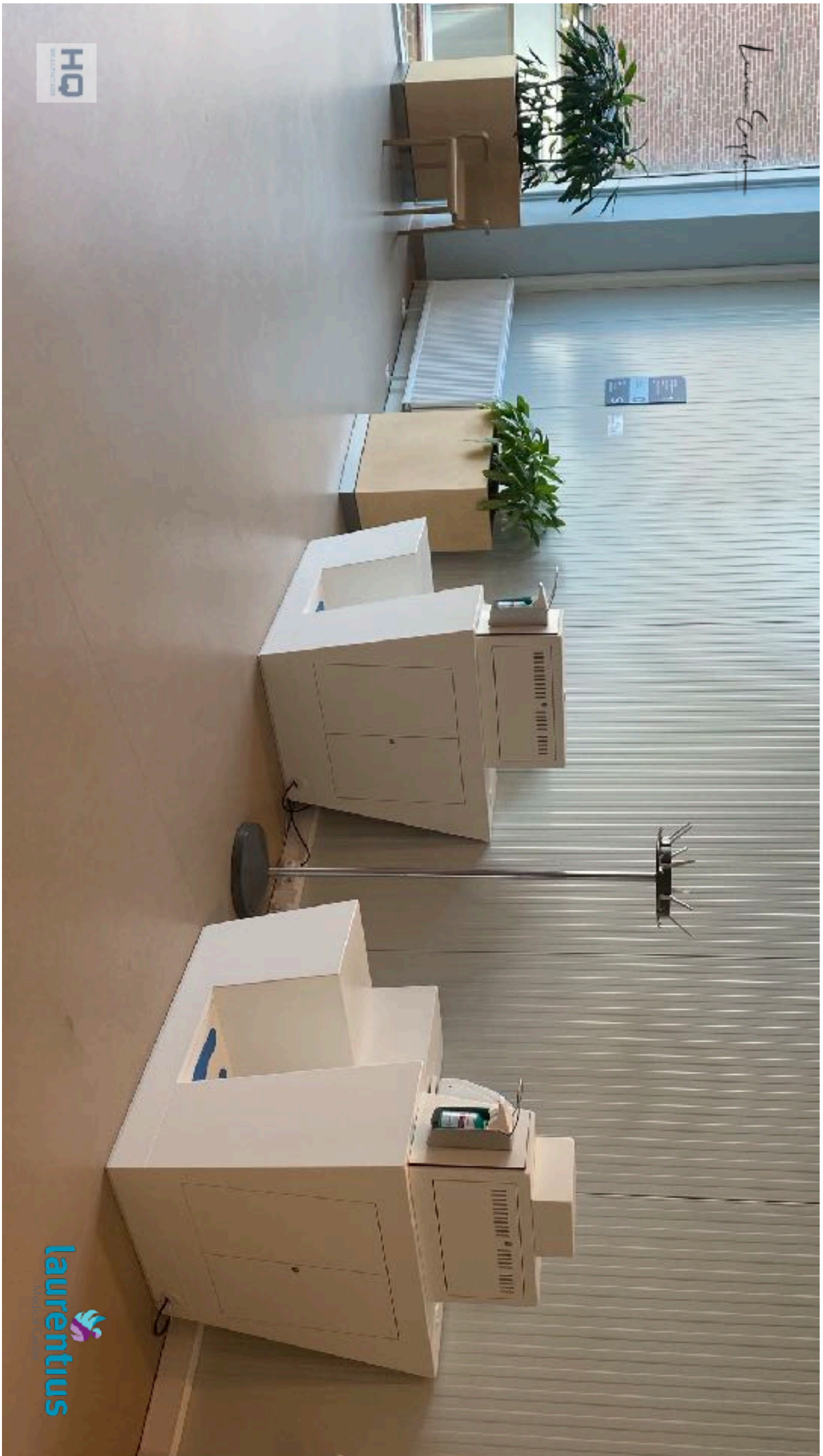

HQ



laurentius

Laurentius Capfion

Luisina Espinoza

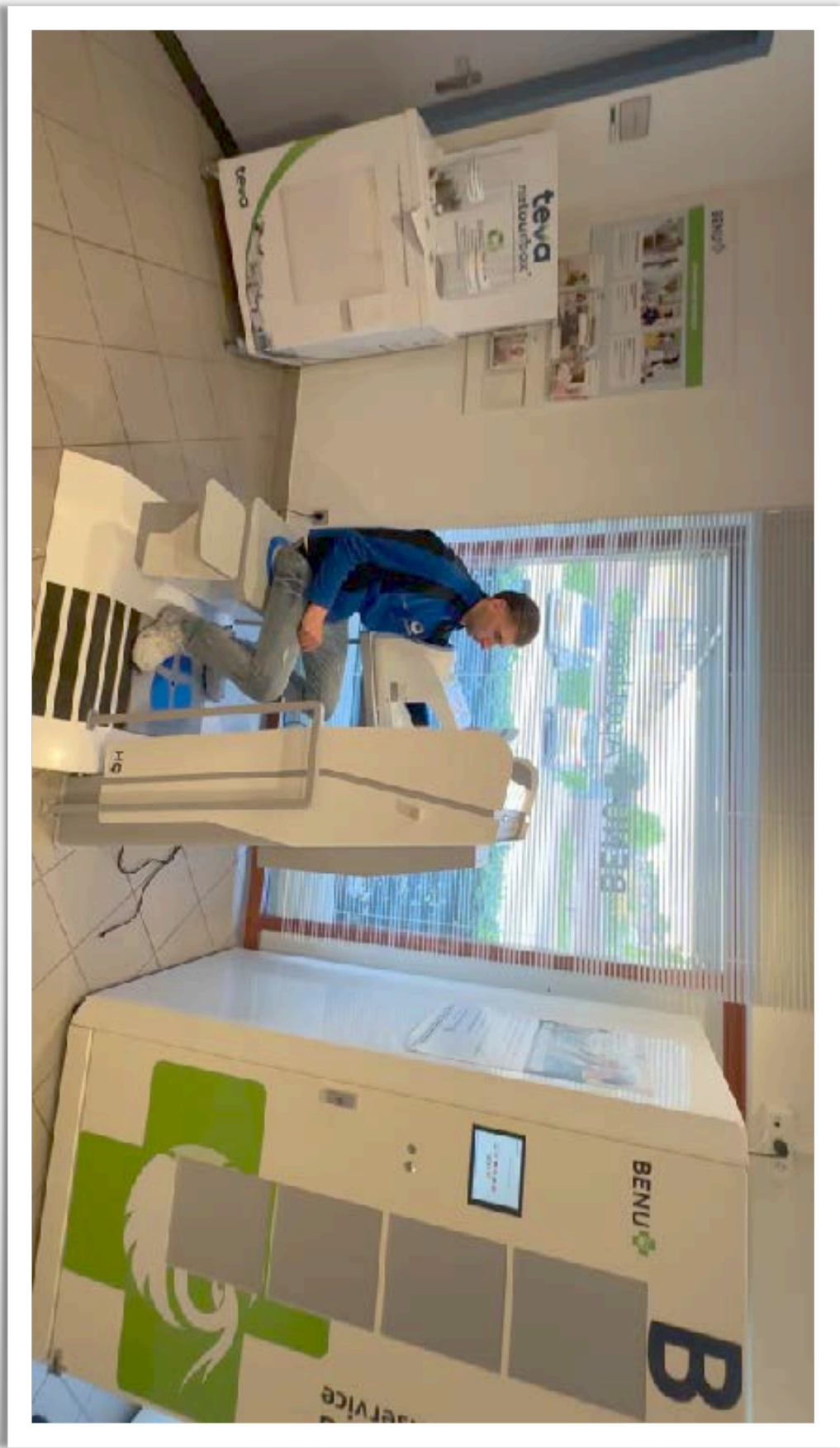

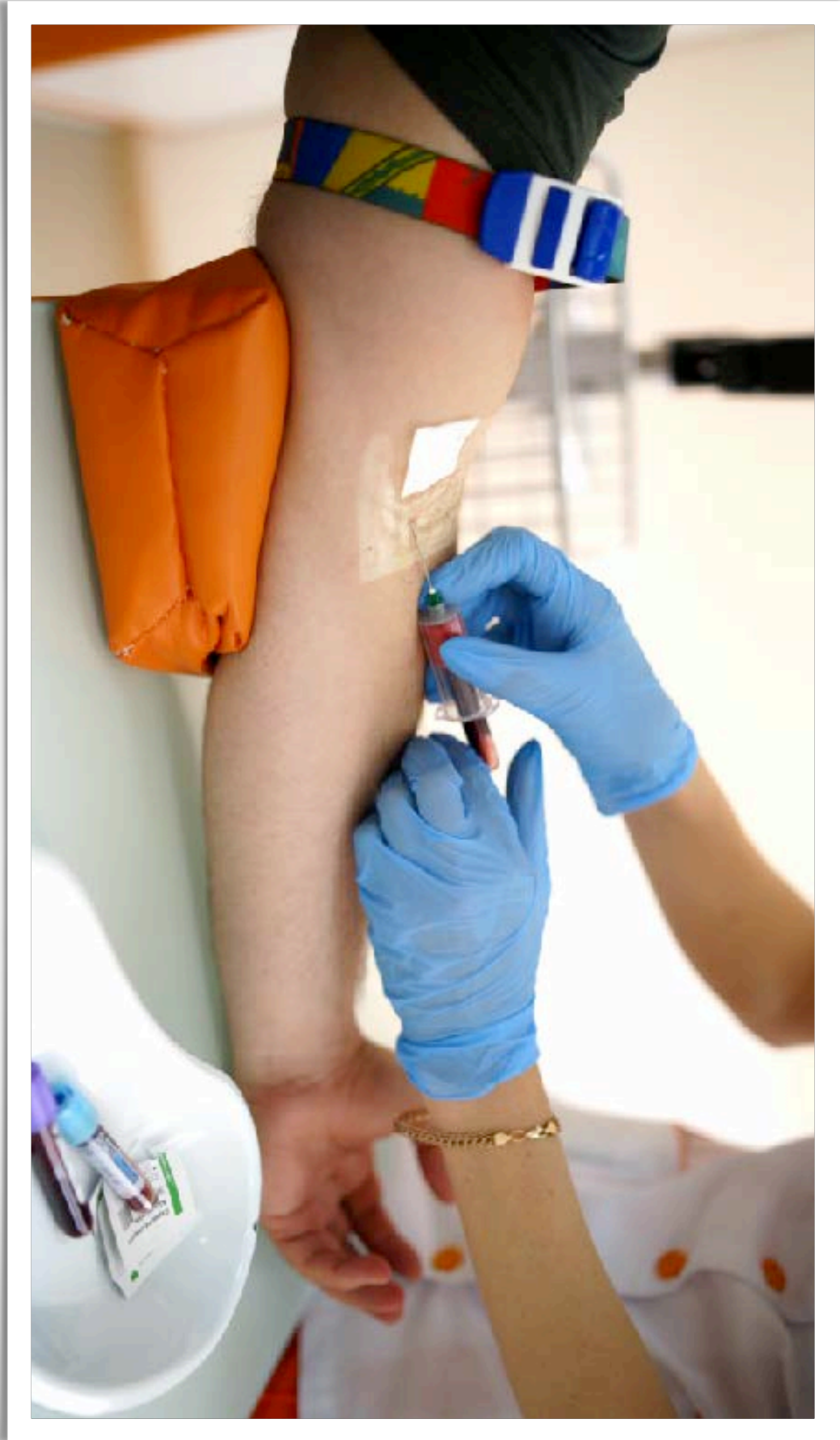



Levin Epstein
PHYSICIAN



Evolution of the Desk

Laura Epton



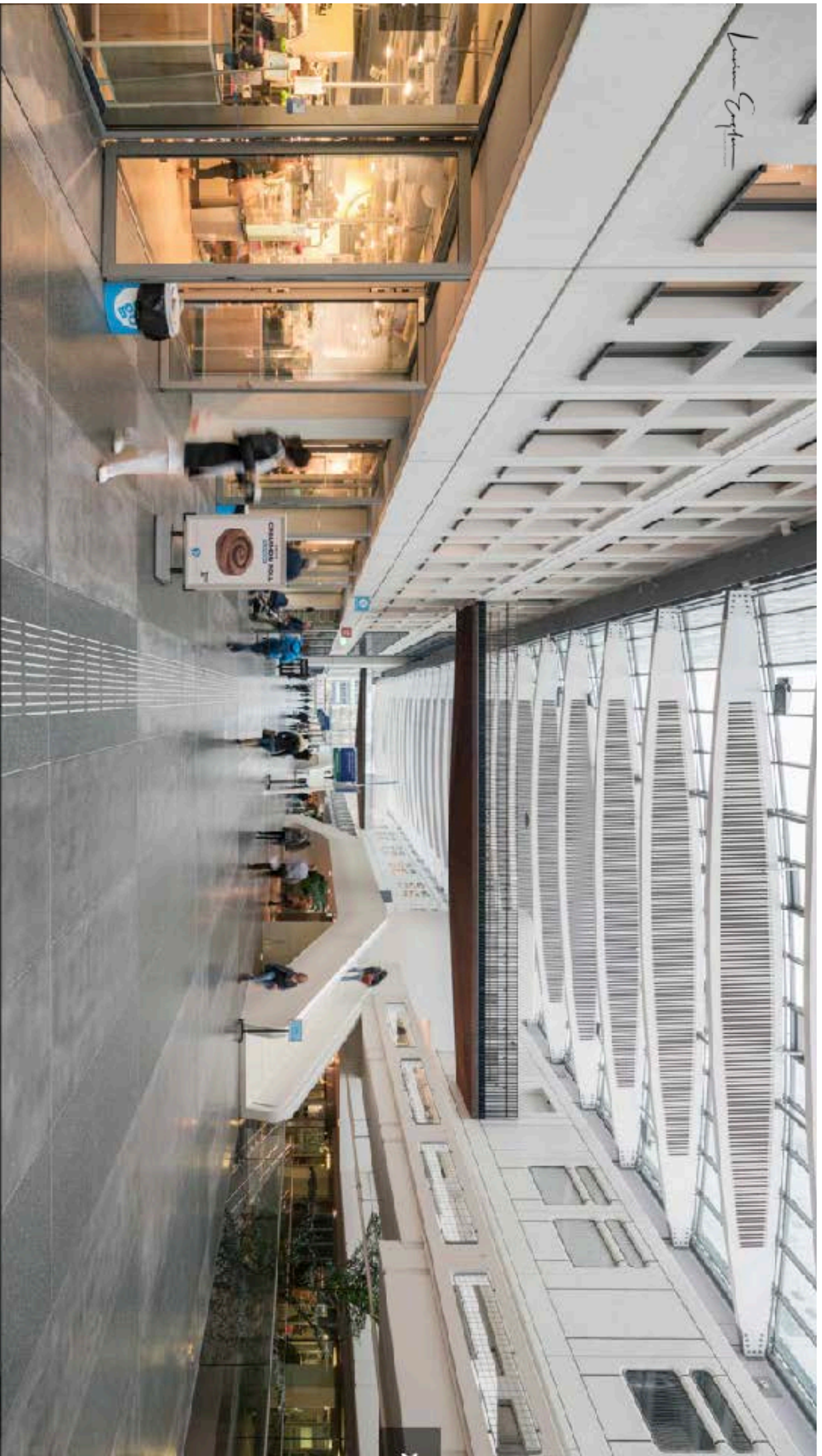



Lumen Systems

Q Perceptive

Public / Private Partnerships



Louise Clayton



Government and Commercial Payers
Incentivizing Collaboration

Increasing adoption of technology



Louise Clayton
H MEETS R
Healthcare meets Retail

PROJECT H

Winkelwagen 2.0

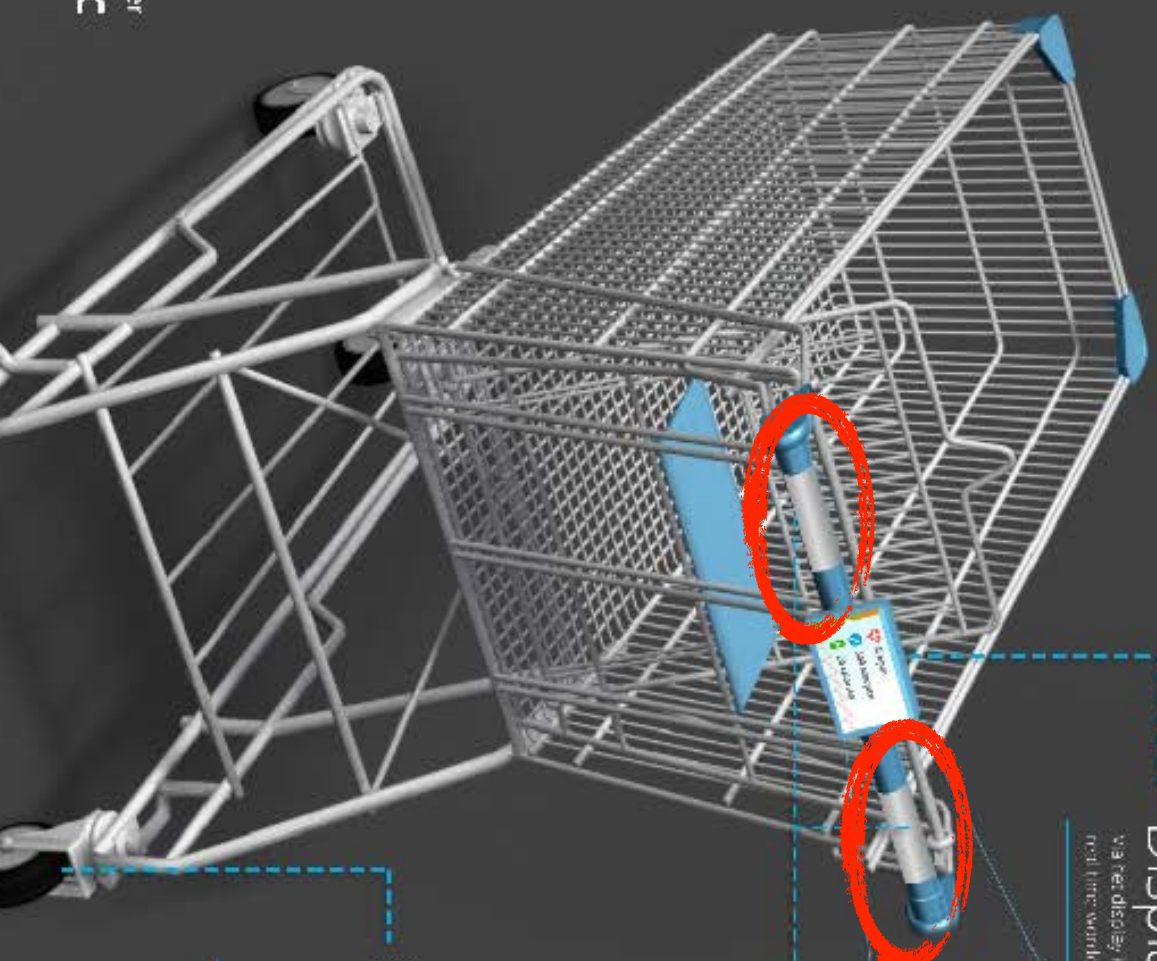

Display
Via het display kunnen de metingen real time worden afgelezen



Electroden
Danijd de elektroden op het handvat van de winkelwagen kunnen metingen van het hart worden gedaan zoals een enkel kantale ECG. Het is nog in het stadium van de ontwikkeling, de metingen kunnen verschillen ook het nauwkeurig, maar dit is de bedoeling.

Stappenteller
Deze geeft de gebruiker informatie over de afstand die is afgelegd in kilometers. De teller kan worden geïntegreerd met de winkelwagen en de gebruiker kan de afstand aflezen op het display van de winkelwagen.



Reshape Center
Radboudumc

HERE IS MY DATA™

Kevin Smit



Luciano Caputo

**Smaller diagnostics lead to different
Points of care, near the patient (citizen)**



Louise Clayton

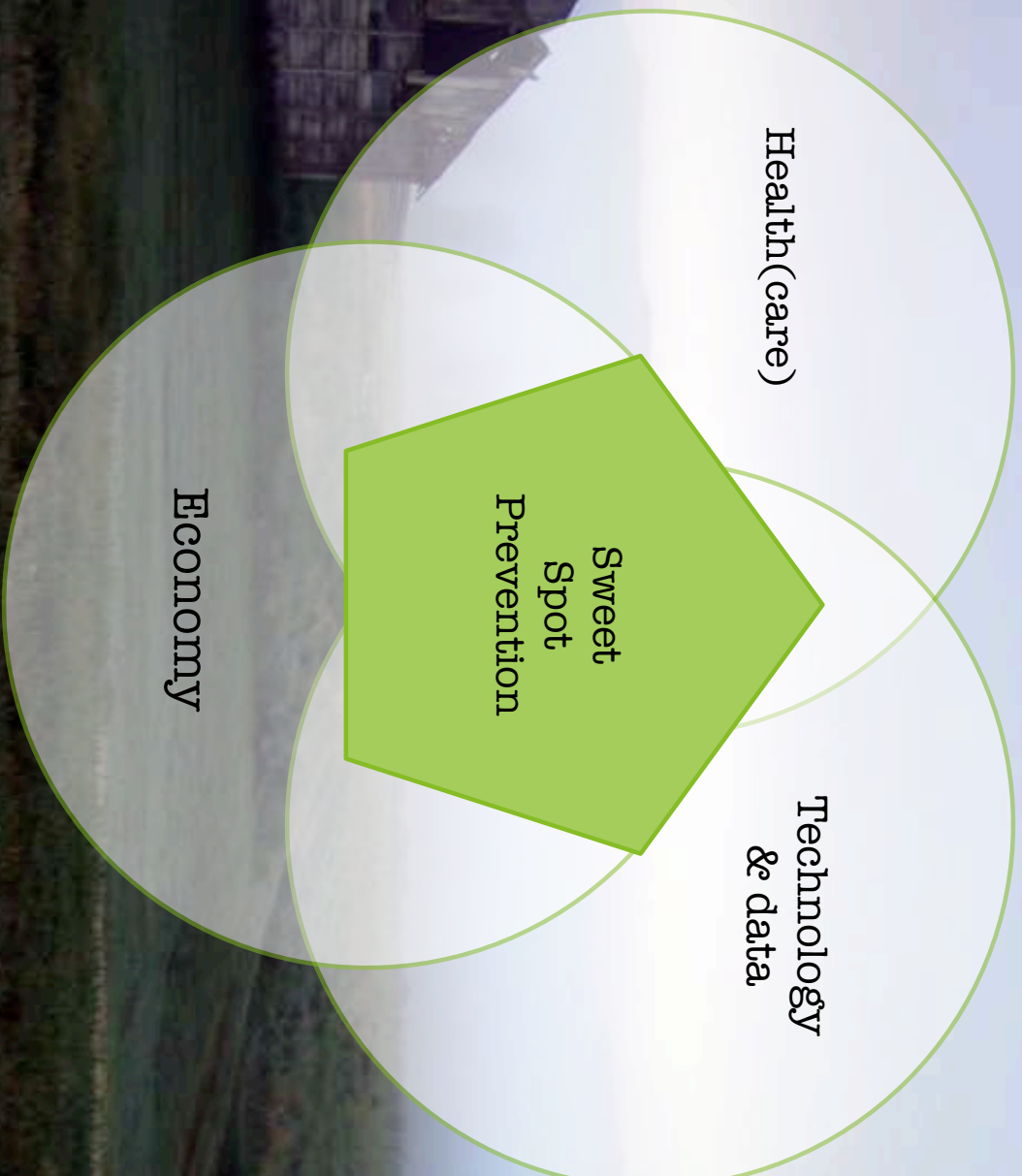

Lucien Saphir

Professional journey



Institution journey



Patient journey



Life journey



Louise Soper

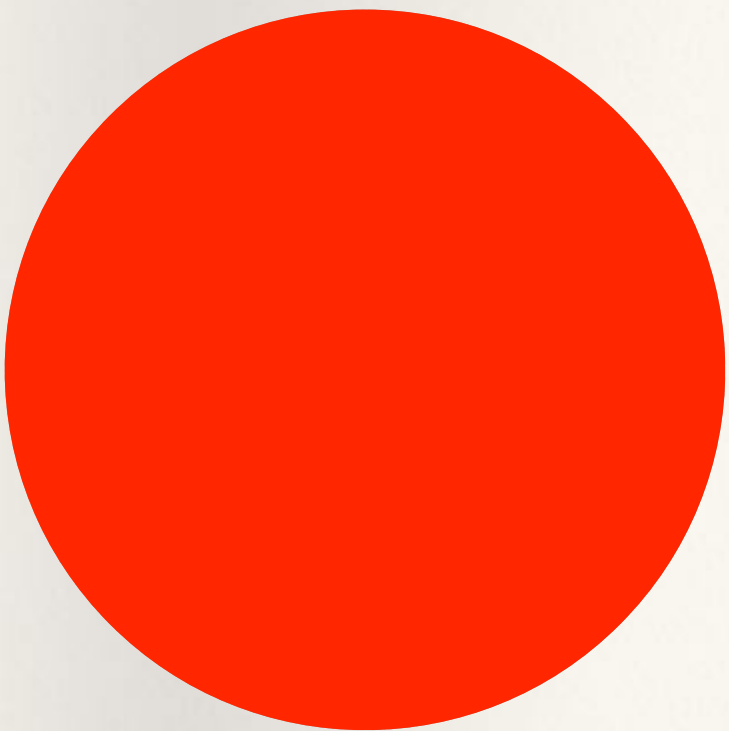

8765:1

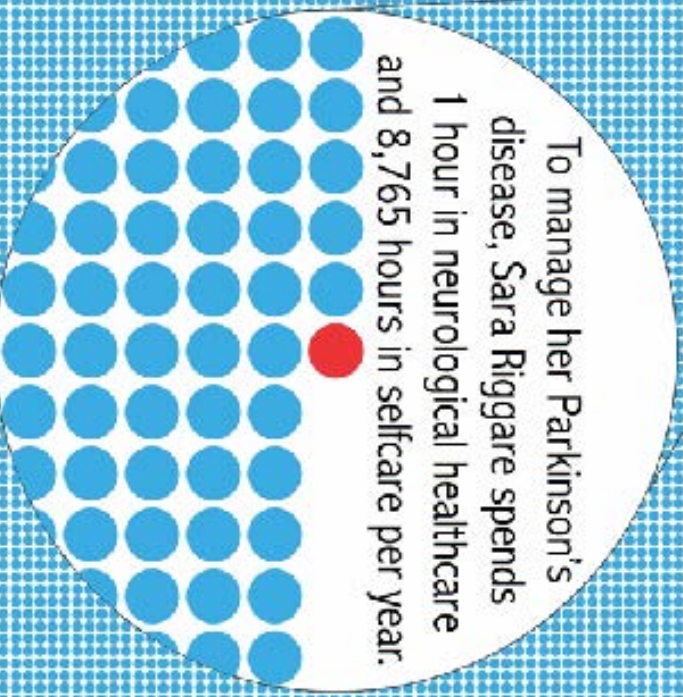

To manage her Parkinson's disease, Sara Riggare spends 1 hour in neurological healthcare and 8,765 hours in selfcare per year.

www.riggare.se

Sara Riggare, 2014

Lucien Engelen

Patients able creating own n=1 communities

via HC IT systems

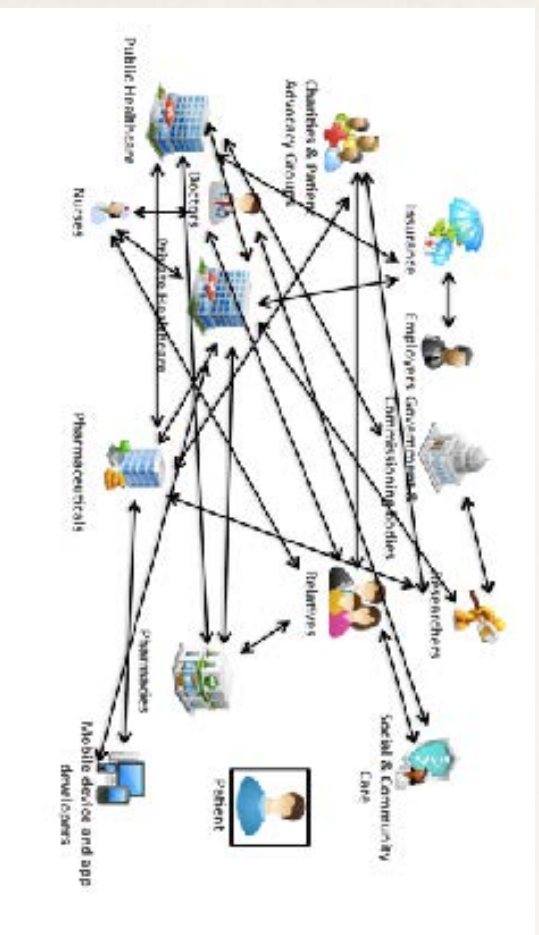

+

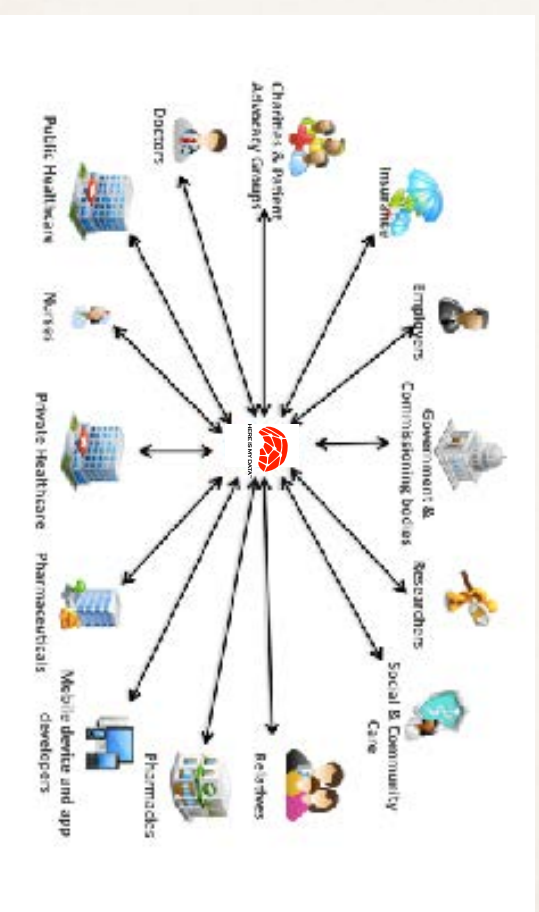

Via the patient

eGo

eCo

Louise Clayton

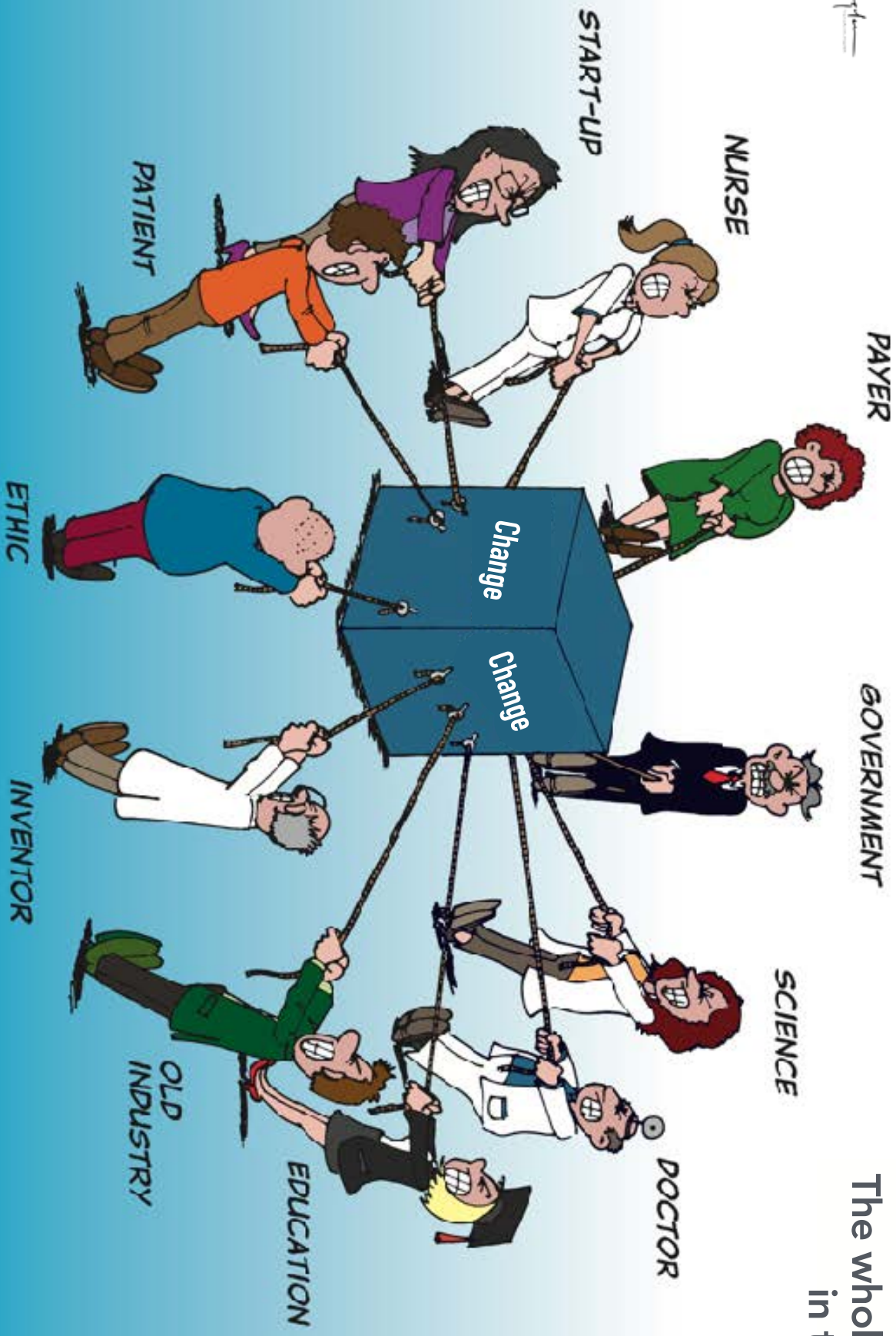

The whole system
in the room

I (Radical)
Unsustainability



III
Consumer
Awakening

II
Technology
(now) available

The Innovation Imperative: 3 Forces

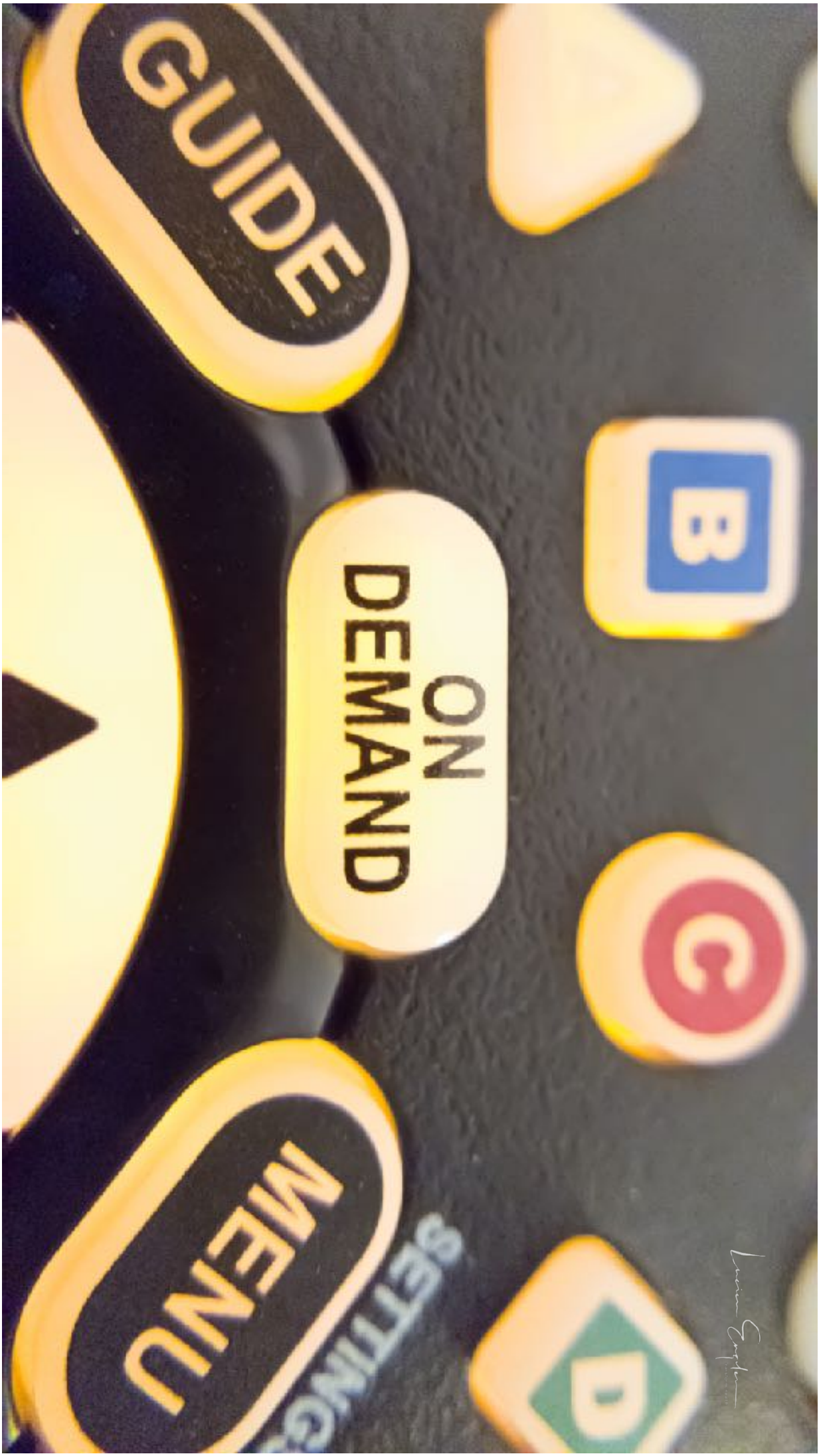

From patients' perspective: Healthcare is 80% blunt logistics



Lucas S. Epstein



Health(care)'s Copernican moment

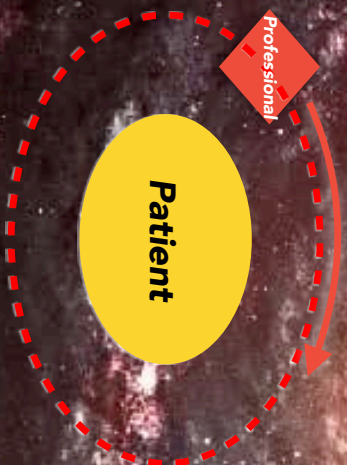
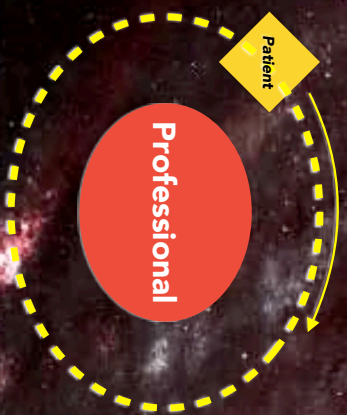

Nicolai
Copernicus
1500

Lucien Engelen

Health(care) is de-localizing ... so is it's data



Laura Epton



Health(care) is the sum of parts

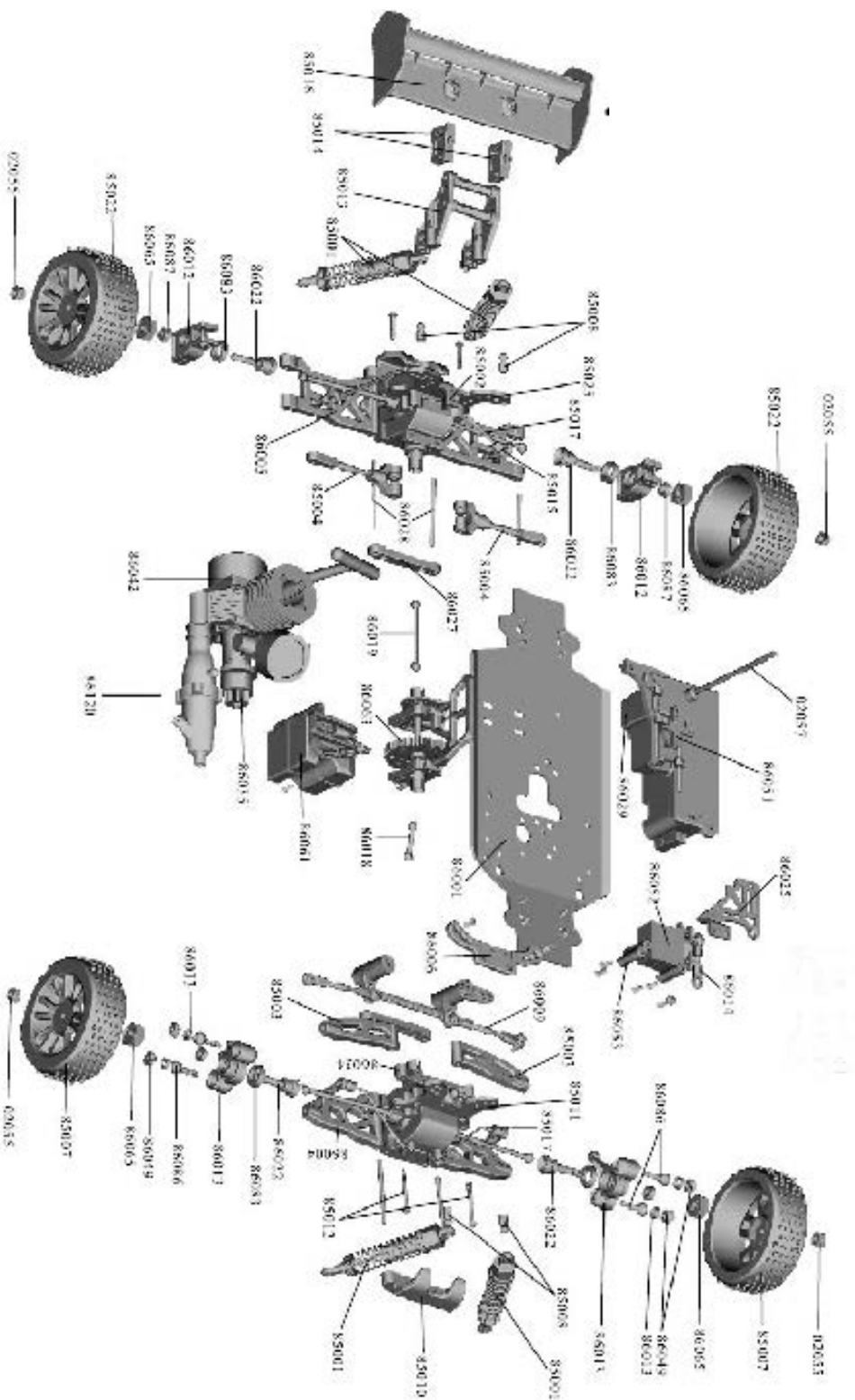

Healthcare will become a software branch.



Lucien Engelen

**Health(care) will
become a
software branch**



4CAST : 'remote' monitoring



Virtual Institutions Telemedicine & Telehealthcenter

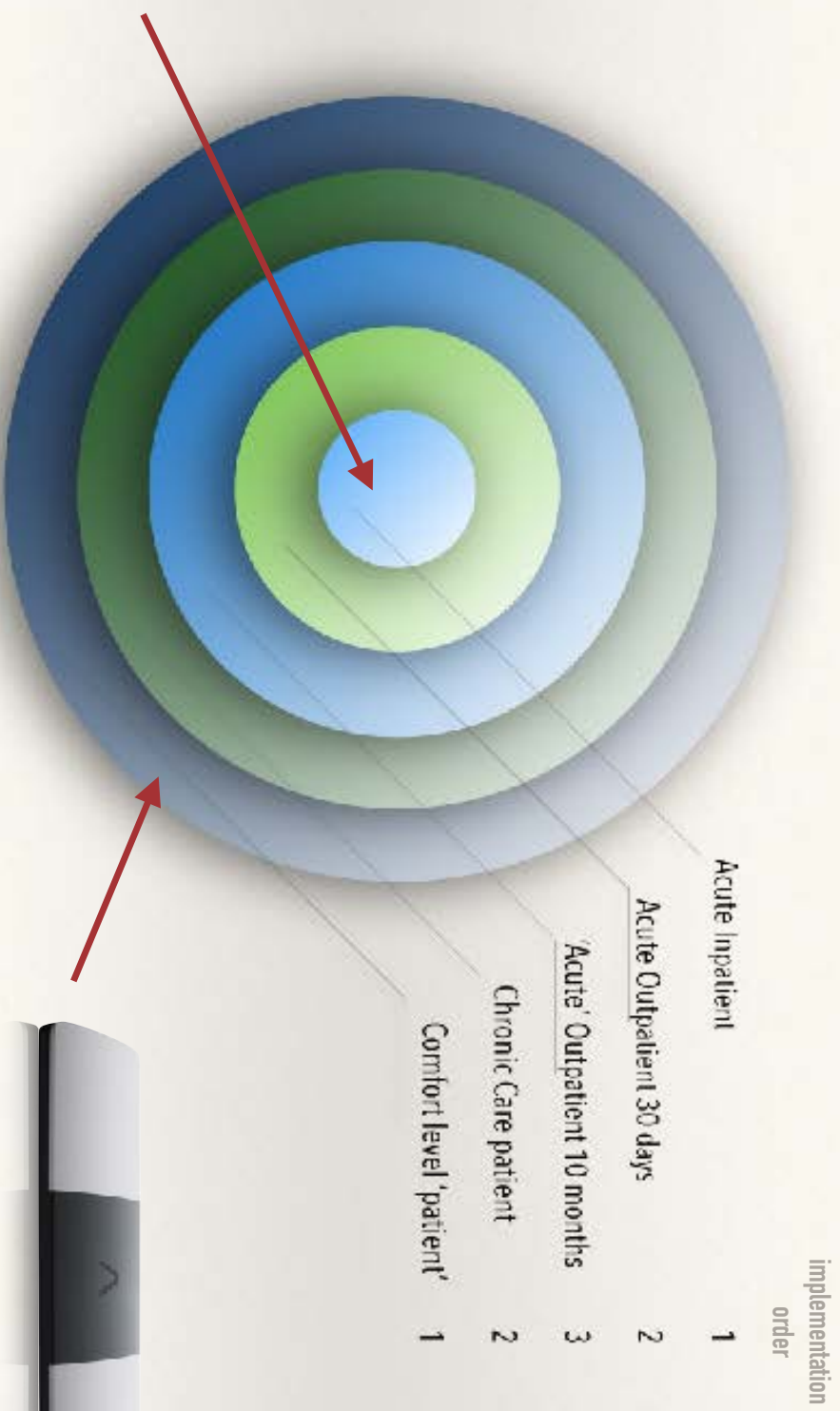

Smart cities for healthy cities

Urban Synthesis
SUSTAINABLE URBAN DESIGN

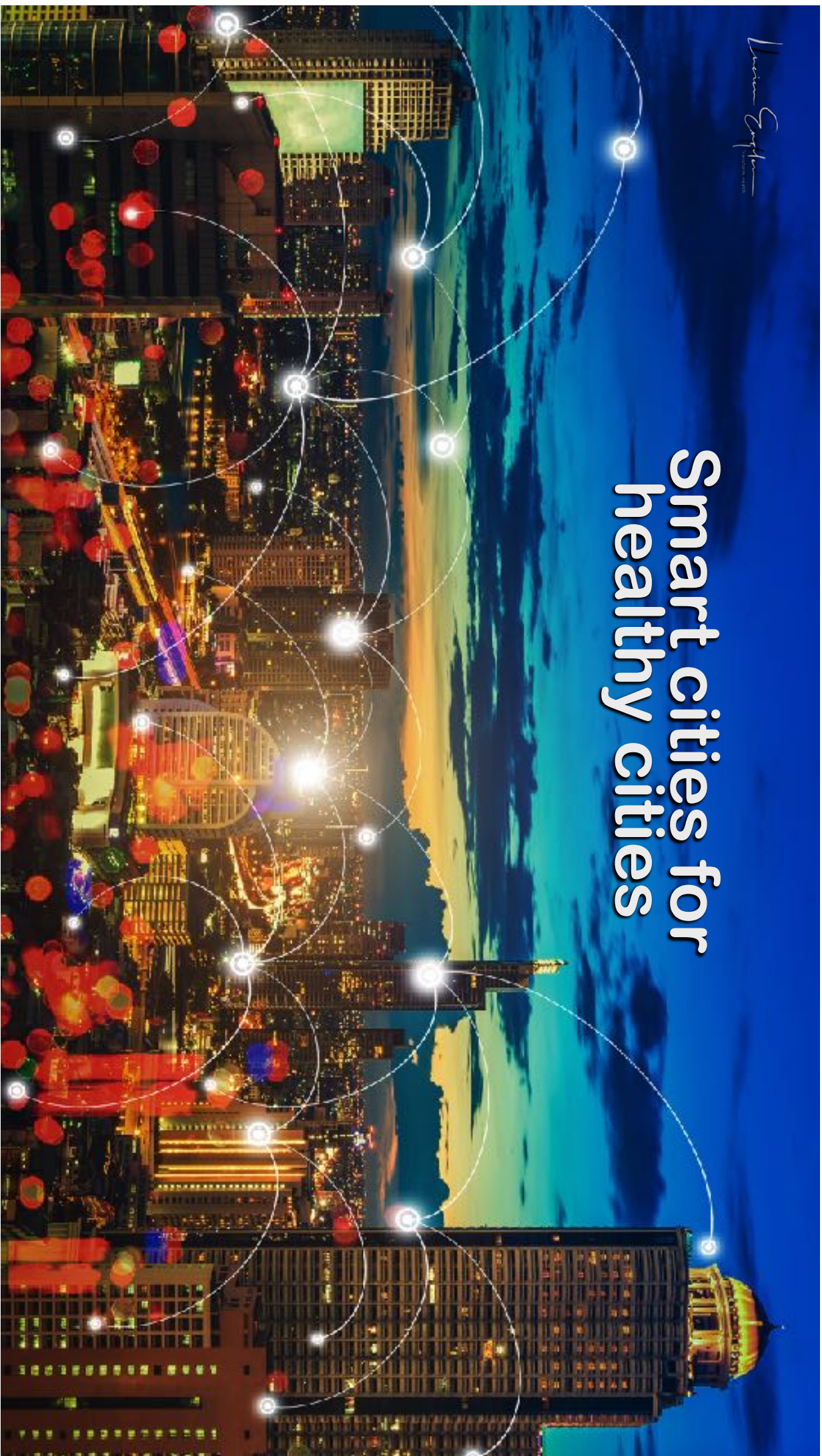

Luciana Caplan

COCAINE SHARKS



Excess drugs in the bloodstream make their way out of the body through urine and fecal matter, and the excreted chemicals flow with the sewage out of our homes.

These drugs can then pass through sewage treatment plants into streams and lakes, where they can be taken up by wildlife and drinking water supplies

Lorenz Engelen

Medical



Observational

Philips

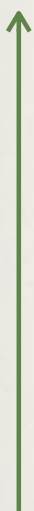

Apple

GE



Samsung

Medtronic



NVIDIA

Pharma



Amazon

Life vitals in clinical patients

To **LIVE** vitals anytime, anywhere, always



Health data now

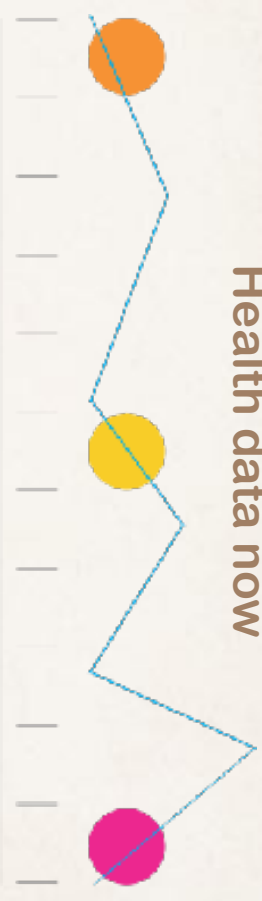

While they need to be
Continuous & Proactive

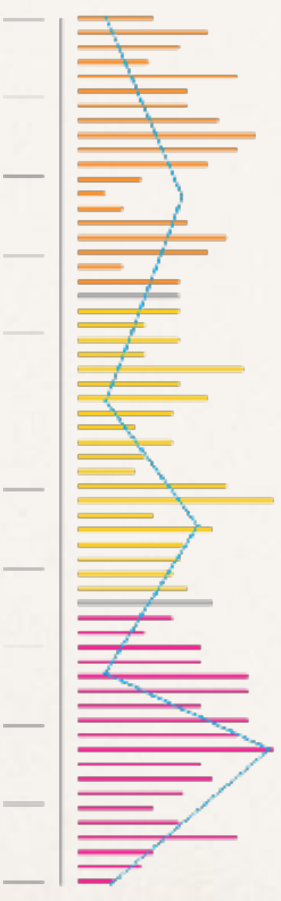

From three times daily to
24/7 continuous monitoring

Lucas Epstein



@luisienengelken

Lucien Engel



Lawson Crispin



For a European
Health Data Space

#HealthUnion

The graphic features a blue-tinted background of a surgical team in an operating room. A large, glowing heart shape is superimposed over the center, composed of a network of colorful nodes and lines in shades of blue, cyan, and magenta. The text 'For a European Health Data Space' is written in white, with 'Health Data Space' in a larger, bold font. The hashtag '#HealthUnion' is located at the bottom left of the graphic.

Laurie S. Kaplan



The International Patient Summary

New data pathway?

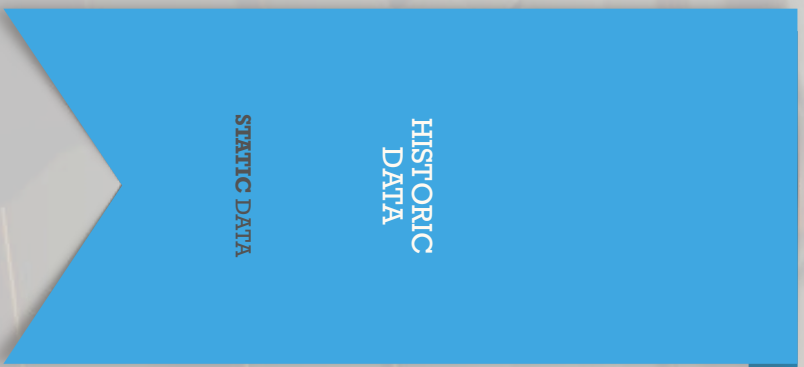



Limburg Noord

Disruptive monitoring with new parameters

Early Warning Heart Rate Variability for drop glucose level

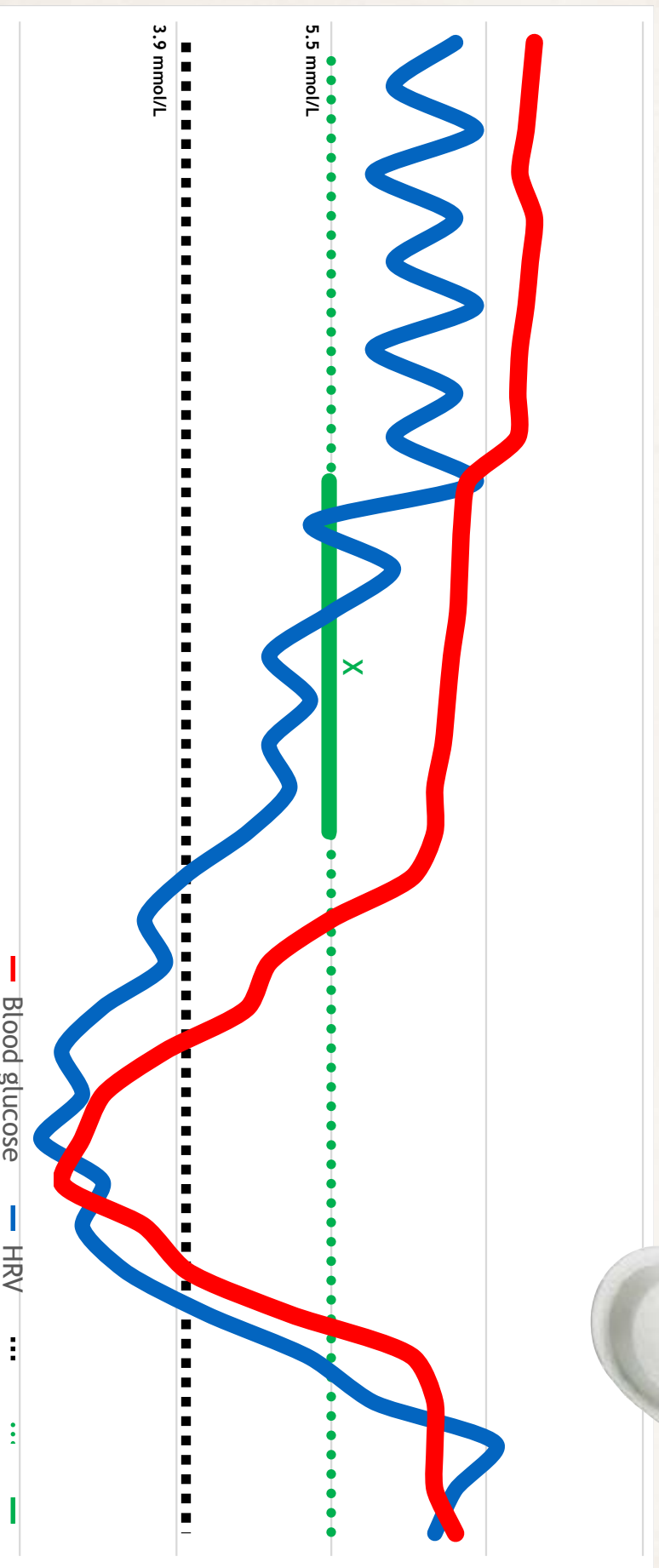

Interval X = 30 minutes

CENTRAL ILLUSTRATION: Flipping the Inverted Pyramid of China's Health Care System for Better Cardiovascular Care

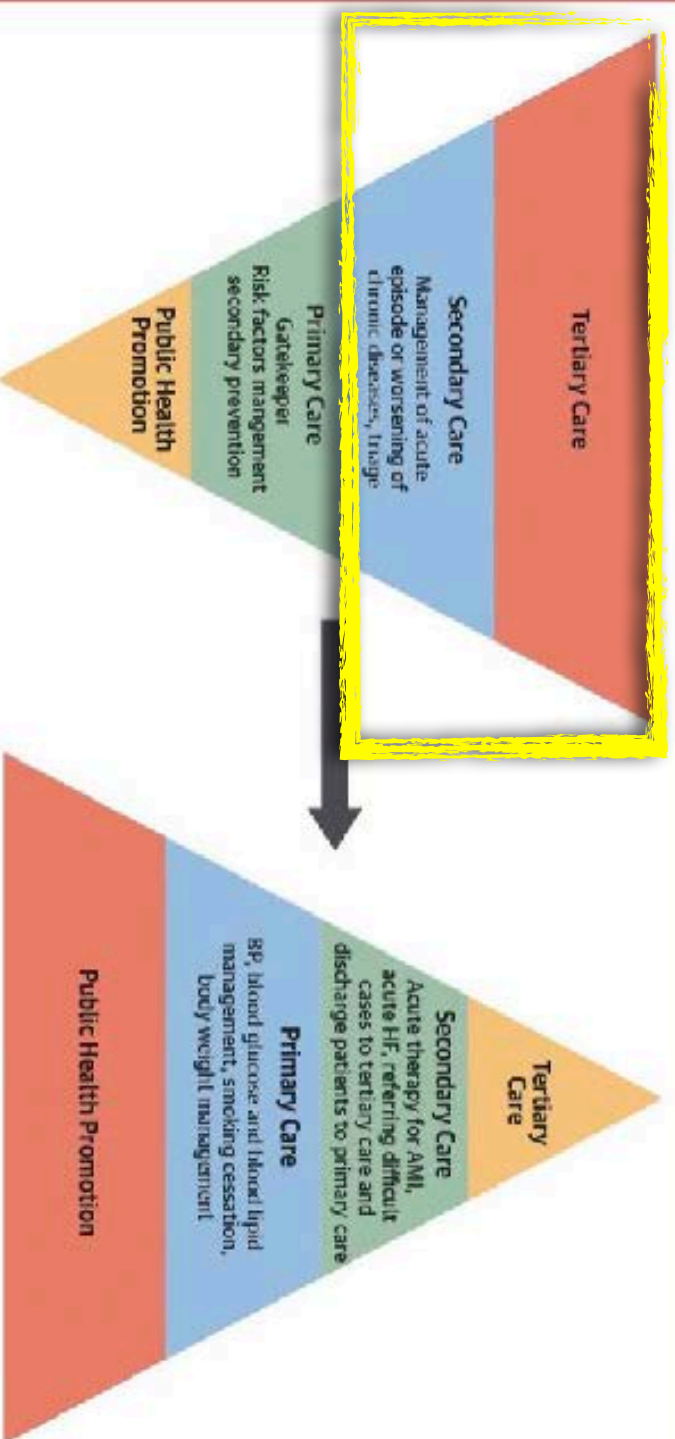

Du, X. et al. J Am Coll Cardiol. 2019;73(24):3135-47.

Xin Du et al. JACC 2019;73:3135-3147

CENTRAL ILLUSTRATION: Flipping the Inverted Pyramid of China's Health Care System for Better Cardiovascular Care

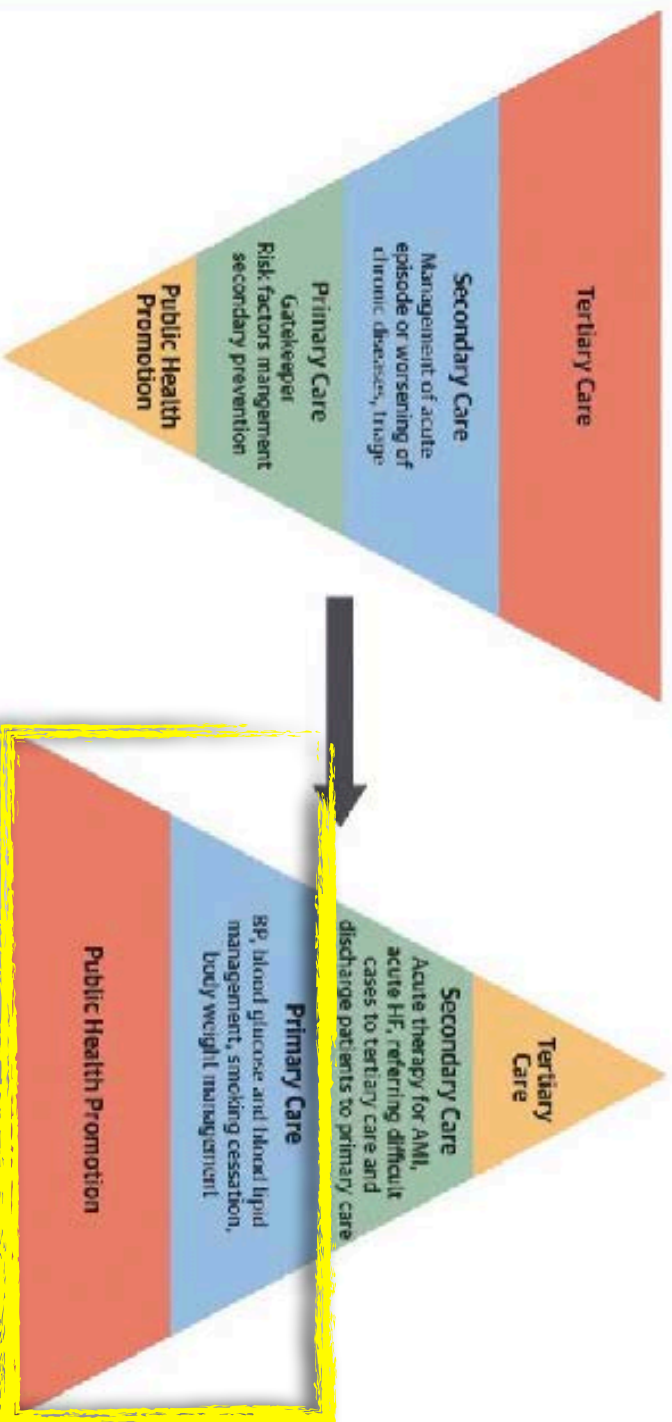

Du, X. et al. *J Am Coll Cardiol.* 2019;73(24):3135-47.

Xin Du et al. *JACC* 2019;73:3135-3147

Luciano Caputo



**Think
Different**

Luisa Saphir

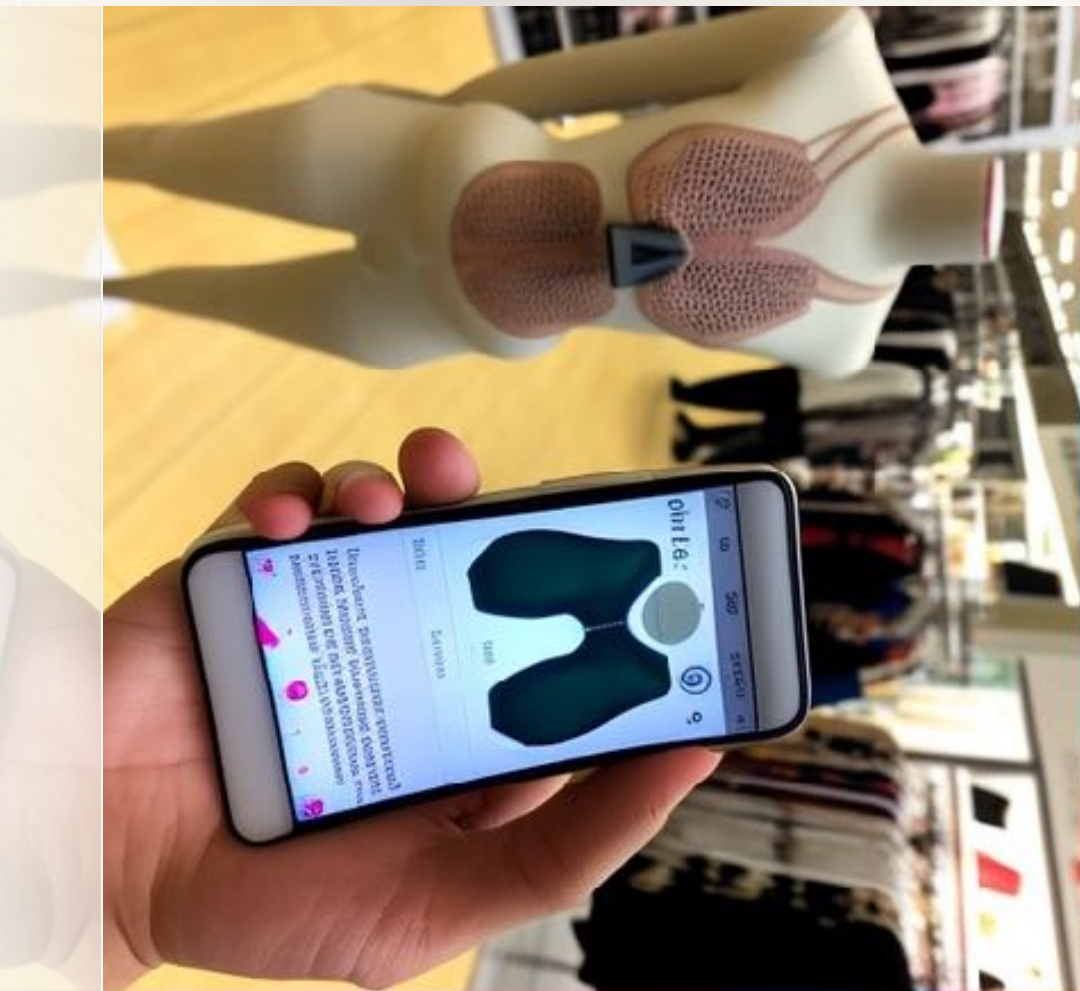

Lucian Creptea



STARECAT.COM

So you took our job ?

Lucien Engelen

It will not take your jobs,
but augmented it

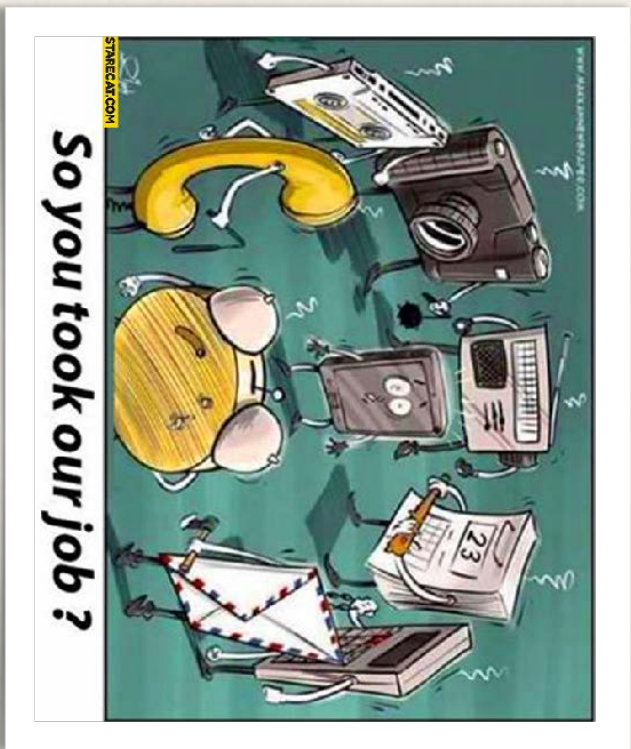

So you took our job ?

AUGMENTED HEALTH

{ CARE }

'THE END
OF THE
BEGINNING'

REVISED VERSION
CHAPTER ADDED

LUCIEN ENGELLEN

"a brilliant summation of the beginning and the joys & actions to
accelerate the future of health and medicine"

Dr. Ted Kraft, MD, Chief for Medical
Simplicity University, Founder & Chair, Executive, MedSoc

Change in health(care)

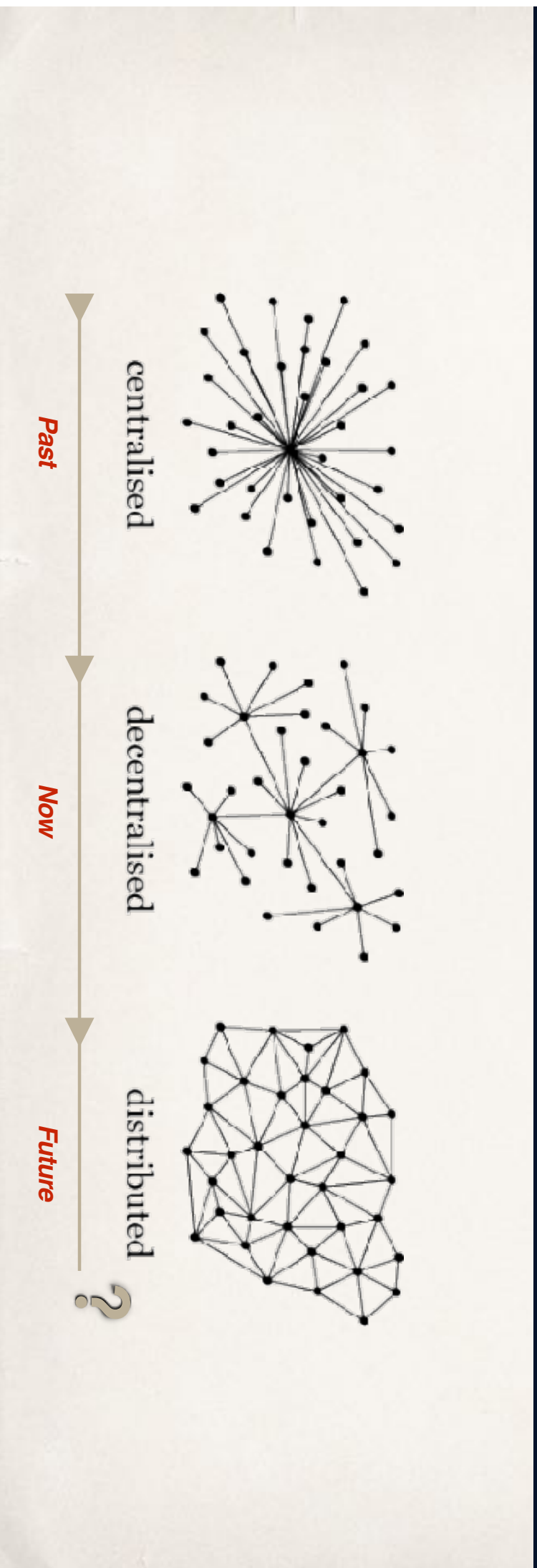

We have the building blocks

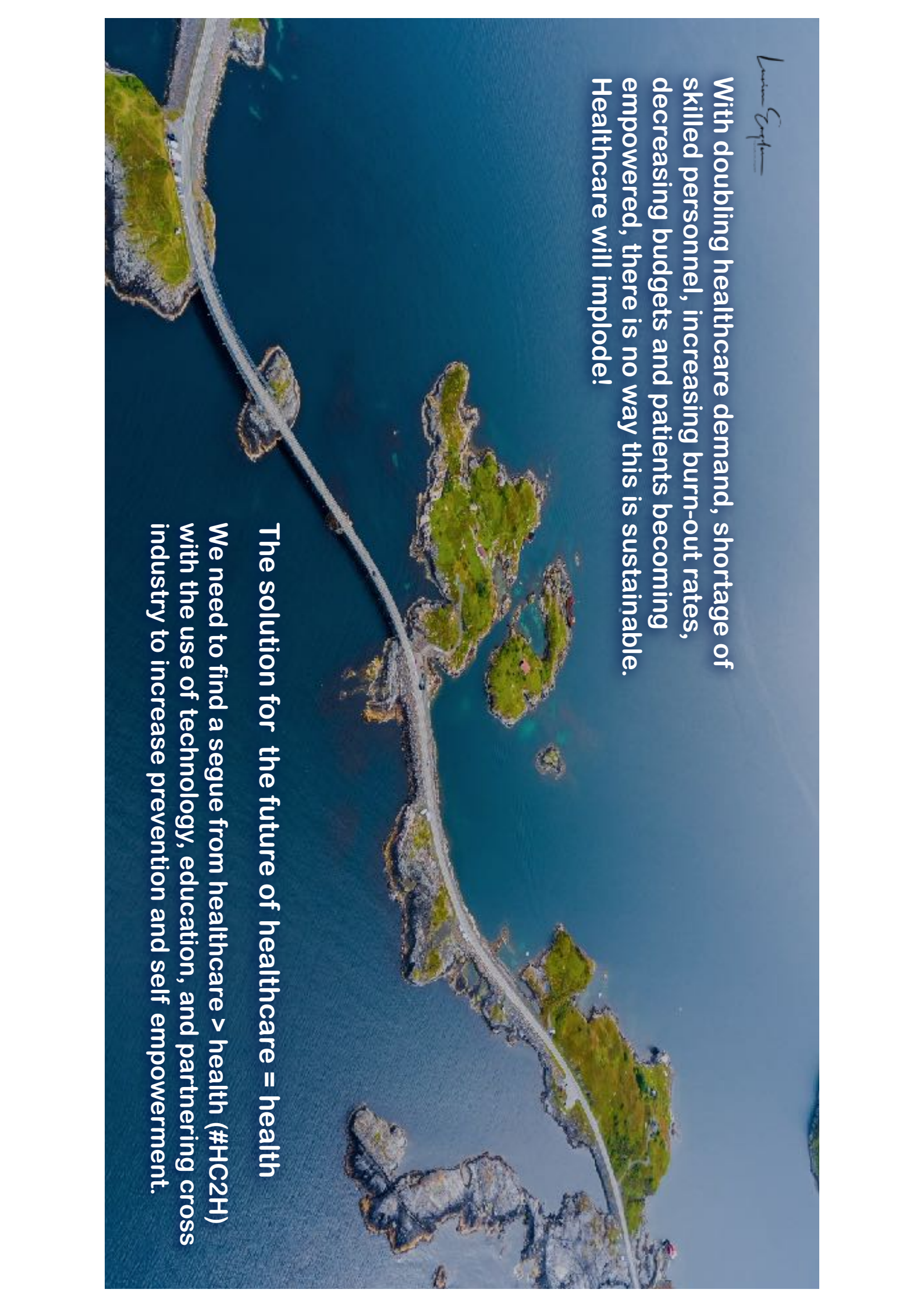

An aerial photograph of a coastal region. A long, narrow road or path runs along the shoreline, connecting several small, green, rocky islands. The water is a deep blue, and the sky is a clear, light blue. The overall scene is serene and scenic.

Laura Epton

With doubling healthcare demand, shortage of skilled personnel, increasing burn-out rates, decreasing budgets and patients becoming empowered, there is no way this is sustainable. Healthcare will implode!

The solution for the future of healthcare = health

We need to find a segue from healthcare > health (#HC2H) with the use of technology, education, and partnering cross industry to increase prevention and self empowerment.

Lucien Engelen



Shift is happening...

- From Healthcare to health
- From hardware to software
- From silo to network
- From centralised to distributed
- Engineering new ECO system
- Combining technology and data
- Somebody needs to do it

Lucien Engel

INNOVATION COMES IN FLAVOURS FOR DIFFERENT PHASES



AWARENESS

0.0 - 1.0



GROUNDWORK

0.8 - 1.2



EXECUTION

1.0 - 100

Example of structure innovation funnel

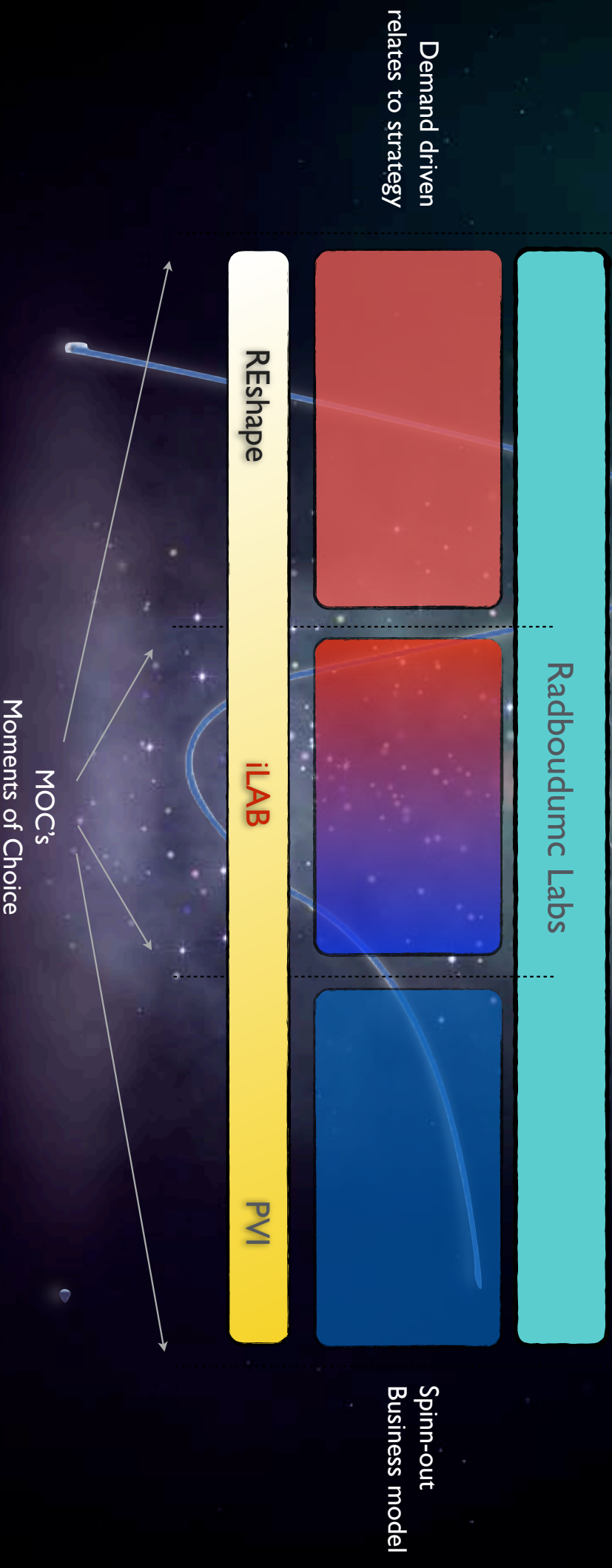

**Digital strategy is not translating
what you do now, digitally.**

**It is completely rethinking
your model grounds-up**

Lucien Engel



Processes & Technology



Culture

Strategy

Leadership

The need

The will

Demolition-team



Image bulb: pavntle.deviantart.com

Culture eats strategy for breakfast

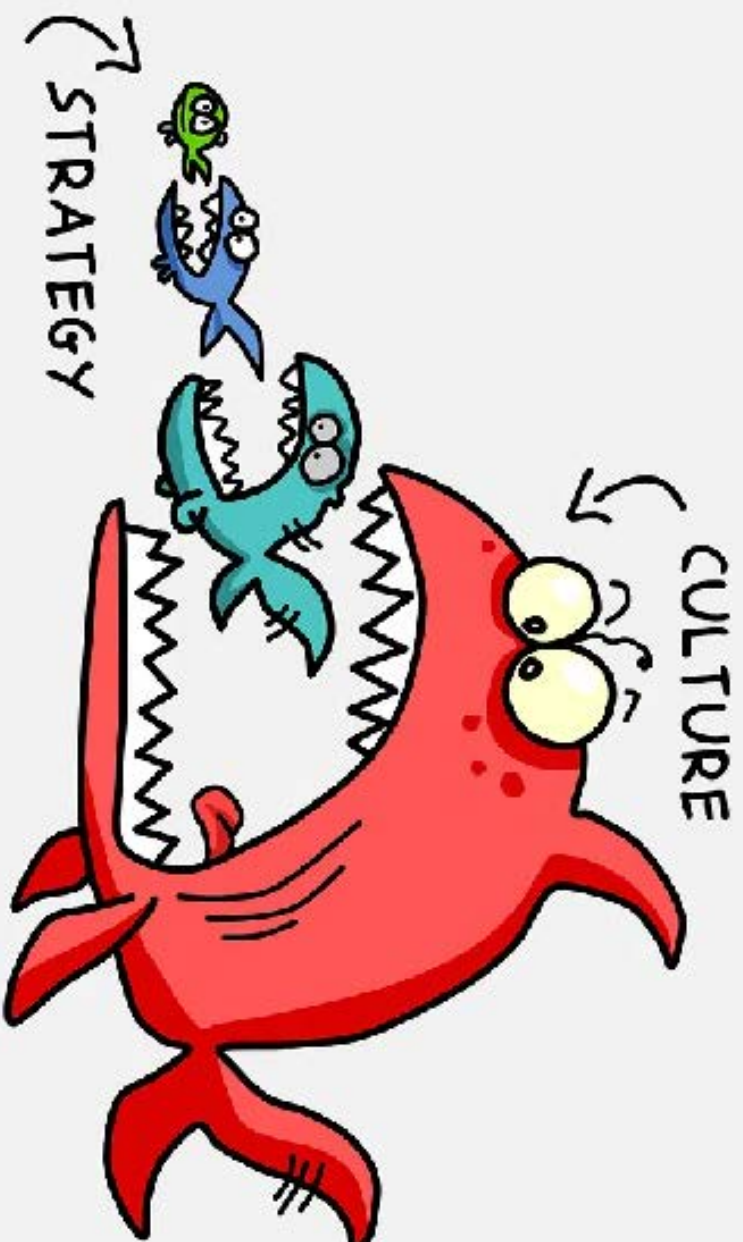

Luca Sestini

ROBERTO FERRARO.ART

Progress

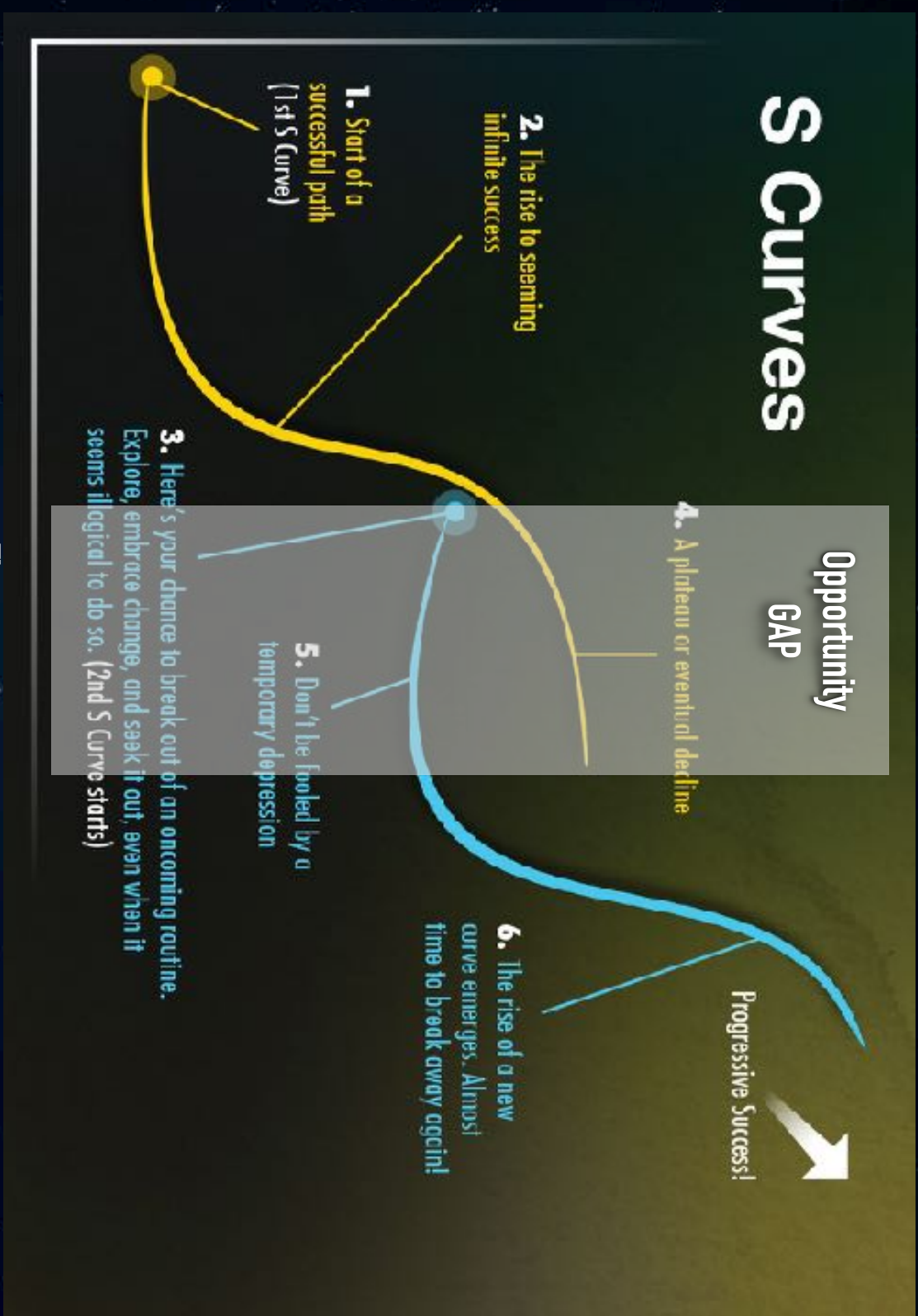

Lucy Griffin



**Delocalized
Democratized
Digital
Dollars**

Data, pattern recognition and AI will drive transformation

Personalised
medicine



Personalised
healthCARE



Personalised
Health

No-quick fix!





Luxury Empire



Laura Caplan

**It takes somewhere
between 7 and 17 years
for innovation in healthcare
to become mainstream**



Luciano Caputo



**Think
Different**



Images simulated

Wishing you all a soft landing into the future



THANK YOU!



Bringing the future a bit closer...



Lucien Engelen 

Health(care) Transformation Maven. International Ambassador Nursing Innovation. (im)Patient. Speaker & Doer.

 **Top Voice**

TransformHealth

Heythuisen, Limburg, Netherlands · [Contact info](#)

793,890 followers · 500+ connections

[Open to](#) [Add profile section](#) 

[Book an appointment](#)